

# Air Freight Container Specifications

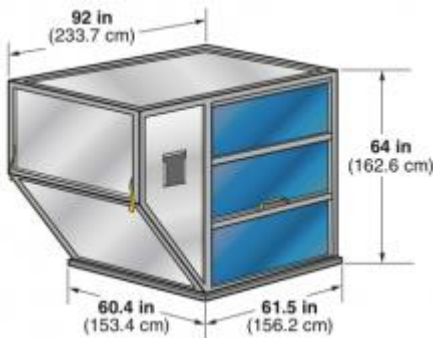

## ULD Container Type: Demi

- **IATA ULD code:** AYY contoured container on half pallet base.
- **Rate class:** Type 7
- **Description:** Half-width main deck container with top contour
- **Suitable for:** 727F, 737F, 757F main deck, 747F, 767F, 777F, DC-10F, MD-11F main deck
- **Maximum gross weight:** 3,016 kg (6,649 lb)
- **Tare weight:** 80 kg (176 lb)
- **AS1825 volume:** 5.8 m<sup>3</sup> (206 ft<sup>3</sup>)



## ULD Container Type: LD-1

- **IATA ULD code:** AKC contoured container
- **Prefixes:** AVC, AVD, AVK, AVJ, and forkable AVY
- **Rate class:** Type 8
- **Description:** Half-width lower hold container with one angled side. Door is either canvas or solid.
- **Loadability:** 747, 767, 777, 787, MD-11 lower hold
- **Door opening:** 147 x 155 cm (58 x 61 in)
- **Maximum gross weight:** 1,588 kg (3,501 lb)
- **Tare weight:** 70 to 170 kg (155 to 375 lb)
- **AS1825 volume:** 5.0 m<sup>3</sup> (175 ft<sup>3</sup>)

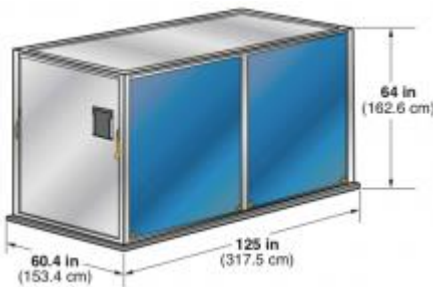

## ULD Container Type: LD-11

- **IATA ULD code:** ALP rectangular container
- **Prefixes:** ALD, AW2, AWB, AWD, AWZ, DLP, DWB, and MWB. Refrigerated version: RWB, RWD, and RWZ.
- **Rate class:** Type 6
- **Description:** Full-width lower hold container. Door is canvas. Center post swings clear for loading. Refrigerated version has solid door.
- **Suitable for:** 747, 777, 787, DC-10, MD-11 lower hold
- **Door opening:** 120 x 61-in (305 x 155-cm)
- **Maximum gross weight:** 3,176 kg (7,002 lb)
- **Tare weight:** 185 kg (408 lb)
- **AS1825 volume:** 7.4 m<sup>3</sup> (262 ft<sup>3</sup>)
- **Boeing volume:** 7.2 m<sup>3</sup> (256 ft<sup>3</sup>)

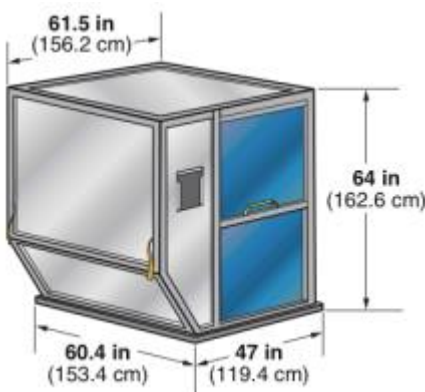

## ULD Container Type: LD-2

- **IATA ULD code:** DPE contoured container
- **Prefixes:** APA, DPA, and forkable DPN
- **Rate class:** Type 8D
- **Description:** Half-width lower hold container with one angled side. Door is either canvas or solid.
- **Suitable for:** 747, 767, 777, 787 lower hold
- **Door opening:** 44 x 60-in (112 x 152-cm)
- **Maximum gross weight:** 1,225 kg (2,700 lb)
- **Tare weight:** 92 kg (203 lb)
- **AS1825 volume:** 3.5 m<sup>3</sup> (124 ft<sup>3</sup>)
- **Boeing volume:** 3.5 m<sup>3</sup> (124 ft<sup>3</sup>)

# Air Freight Container Specifications

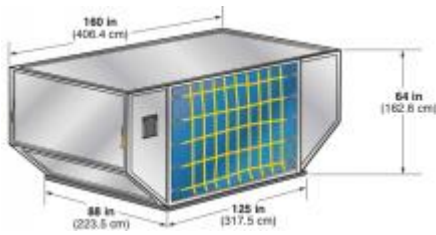

## ULD Container Type: LD-26

- IATA ULD code AAF contoured container on P1P base
- Rate class: Type 5
- Description: Full-width lower hold container angled at both ends. Door is canvas with built-in net door straps.
- Suitable for: 747, 777, 787, DC-10, MD-11 lower hold
- Door opening: 120 x 60-in (305 x 152-cm)
- Maximum gross weight: 6,033 kg (13,300 lb)
- Tare weight: 250 kg (551 lb)
- AS1825 volume: 13.3 m<sup>3</sup> (470 ft<sup>3</sup>)

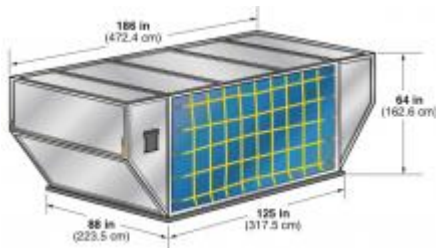

## ULD Container Type: LD-29

- IATA ULD code AAU contoured container on P1P base
- Rate class: Type 5
- Description: Full-width lower hold container angled at both ends. Door is canvas with built-in net door straps.
- Suitable for: 747 lower hold Door opening: 118 x 60-in (300 x 152-cm)
- Maximum gross weight: 6,033 kg (13,300 lb)
- Tare weight: 265 kg (584 lb)
- AS1825 volume: 14.4 m<sup>3</sup> (510 ft<sup>3</sup>)



## ULD Container Type: LD-29 Reefer

- IATA ULD code RAU contoured cool container on P1P base.
- Rate class: Type 5
- Description: Full-width lower hold container angled at both ends. Refrigerated version of AAU has solid door.
- Suitable for: 747 lower hold
- Door opening: 118 x 60-in (300 x 152-cm)
- Maximum gross weight: 6,033 kg (13,300 lb)
- Tare weight: 450 kg (992 lb)
- Internal volume: 11.1 m<sup>3</sup> (392 ft<sup>3</sup>)

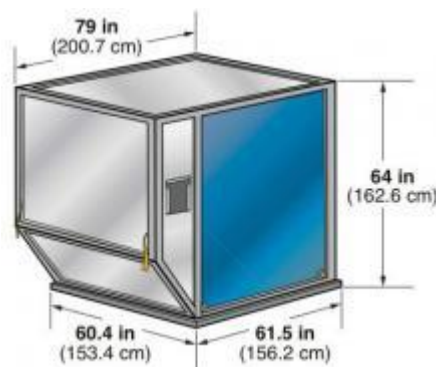

## ULD Container Type: LD-3

- IATA ULD code: AKE contoured container
- Prefixes: AKE, AVA, AVB, AVC, AVK, DVA, DVE, DVP, XKS, XKG, and forkable AKN, AVN, DKN, DVN, and XKN
- Rate class: Type 8
- Description: Half-width lower deck container with one angled side. Door is either canvas or solid.
- Loadability: A300, A310, A330, A340, 747, 767, 777, DC-10, MD-11, and L-1011
- Door opening: 58 x 61 in (147 x 155 cm)
- Maximum gross weight: 3,500 lb (1,588 cm)
- Tare weight: 181 lb (82 kg)
- AS1825 volume: 159 ft<sup>3</sup> (4.5 m<sup>3</sup>)

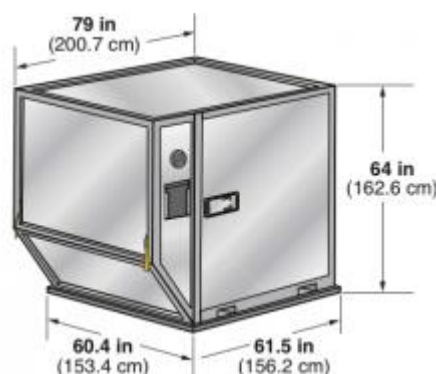

## ULD Container Type: LD-3 Reefer

- IATA ULD code: RKN contoured cool container
- Prefixes: RVN
- Rate class: Type 8
- Description: Half-width lower hold insulated container with one angled end. Door is solid. Most examples are forkable.
- Suitable for: 747, 767, 777, 787, DC-10, MD-11 lower hold
- Door opening: 54 x 55-in
- Maximum gross weight: 1,588 cm (3,500 lb)
- Tare weight: 210 kg (463 lb)
- AS1825 volume: 4.5 m<sup>3</sup> (159 ft<sup>3</sup>) plus internal volume (as is)

# Air Freight Container Specifications

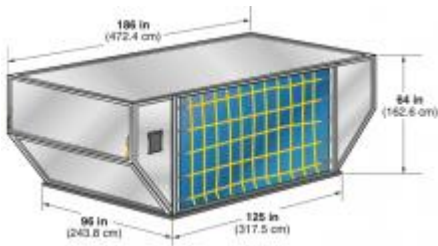

## ULD Container Type: LD-39

- IATA ULD code: AMU contoured container on P6P base
- Rate class: Type 2BG
- Description: Full-width lower hold container angled at both ends. Door is canvas with built-in net door straps.
- Suitable for: 747 lower hold
- Door opening: 120 x 60-in (305 x 152-cm)
- Maximum gross weight: 5,035 kg (11,100 lb)
- Tare weight: 290 kg (639 lb)
- AS1825 volume: 15.9 m<sup>3</sup> (560 ft<sup>3</sup>)

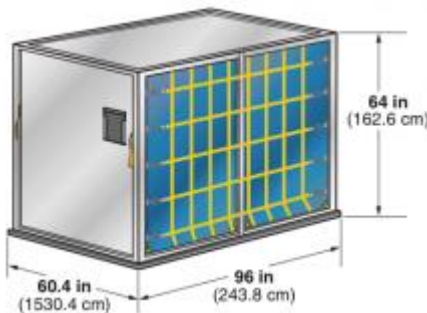

## ULD Container Type: LD-4

- IATA ULD code: ALP rectangular container
- Prefixes: ALD, AWD, AWZ, DLP, and forkable ALB, ALC, AWB, and AWC
- Rate class: Type 8
- Description: Full-width lower hold container. Door is canvas with built-in door straps.
- Suitable for: 767, 777, 787 lower hold
- Door opening: 92 x 61-in (234 x 155-cm)
- Maximum gross weight: 2,449 kg (5,399 lb)
- Tare weight: 120 kg (264 lb)
- AS1825 volume: 5.7 m<sup>3</sup> (200 ft<sup>3</sup>)
- Boeing volume: 5.5 m<sup>3</sup> (195 ft<sup>3</sup>)

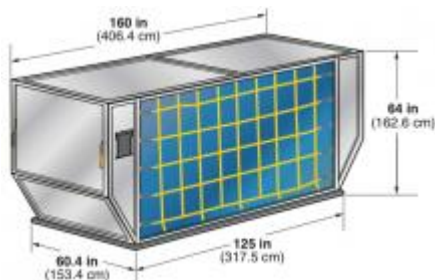

## ULD Container Type: LD-6

- IATA ULD code: ALF contoured container
- Prefixes: AWA, AWF, and forkable AWC
- Rate class: Type 6W
- Description: Full-width lower hold container with angled ends. Door is canvas with built-in door straps.
- Suitable for: 747, 777, 787, DC-10, MD-11 lower hold
- Door opening: 120 x 60-in (305 x 152-cm)
- Maximum gross weight: 3,175 kg (7,000 lb)
- Tare weight: 230 kg (507 lb)
- AS1825 volume: 9.1 m<sup>3</sup> (322 ft<sup>3</sup>)
- Boeing volume: 8.9 m<sup>3</sup> (316 ft<sup>3</sup>)

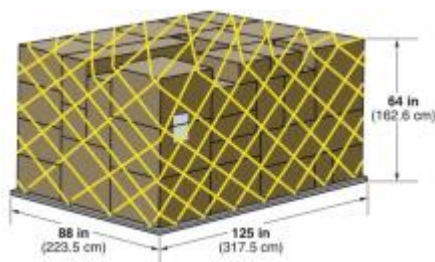

## ULD Container Type: LD-7

- IATA ULD code: P1P flat pallet with net
- Prefixes: PAA, PAG, PAJ, PAP, PAX, P1A, P1C, P1D, and P1G
- Rate class: Type 5
- Description: Universal general-purpose flat pallet for lower holds and main decks.
- Suitable for:
  - Widebody: All aircraft lower holds and main decks
  - Standard-body: 707F, 727F, 737F, 757F, DC8F, DC9F main decks
- Maximum gross weight: 4,626 kg (10,198 lb)
- Tare weight: 105 kg (231 lb)
- AS1825 volume: 10.5 m<sup>3</sup> (370 ft<sup>3</sup>)
- Boeing volume: 10.7 m<sup>3</sup> (379 ft<sup>3</sup>)

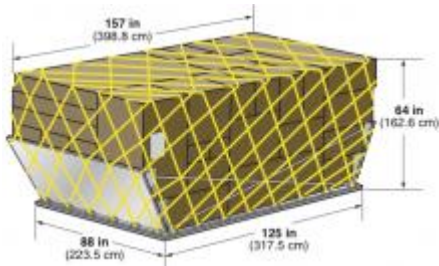

## ULD Container Type: LD-7 with Angled Wings

- **IATA ULD code:** XAW P1P pallet with fixed-angle wings and net
- **Rate class:** Type 5
- **Description:** P1P base with fixed wings for overhang.
- **Suitable for:** 747, 777, 787, DC-10, MD-11 lower holds
- **Maximum gross weight:** 5,000 kg (11,023 lb)
- **Tare weight:** 170 kg (375 lb)
- **AS1825 volume:** 14.0 m<sup>3</sup> (495 ft<sup>3</sup>)

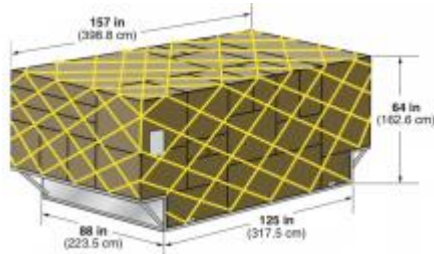

## ULD Container Type: LD-7 with Folded Wings

- **IATA ULD code:** PAD P1P pallet with folding wings and net
- **Prefixes:** PAX and P1X
- **Rate class:** Type 5
- **Description:** P1P base with folding wings for overhang.
- **Suitable for:** 747, 777, 787, DC-10, MD-11 lower holds
- **Maximum gross weight:** 5,000 kg (11,023 lb)
- **Tare weight:** 152 kg (335 lb)
- **AS1825 volume:** 14.0 m<sup>3</sup> (495 ft<sup>3</sup>)

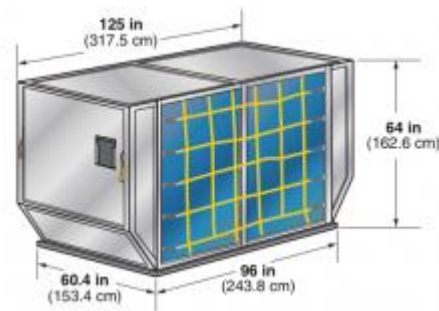

## ULD Container Type: LD-8

- **IATA ULD code:** DQF
- **Prefixes:** ALE, ALN, DLE, DLF, DQP, and MQP
- **Rate class:** Type 6A
- **Description:** Full-width lower hold container angled at both ends. Door is canvas with built-in door straps.
- **Suitable for:** 767, 787 lower hold
- **Door opening:** 92 x 62-in (234 x 157-cm)
- **Maximum gross weight:** 2,450 kg (5,401 lb)
- **Tare weight:** 127 kg (280 lb)
- **AS1825 volume:** 7.1 m<sup>3</sup> (252 ft<sup>3</sup>)
- **Boeing volume:** 6.9 m<sup>3</sup> (245 ft<sup>3</sup>)

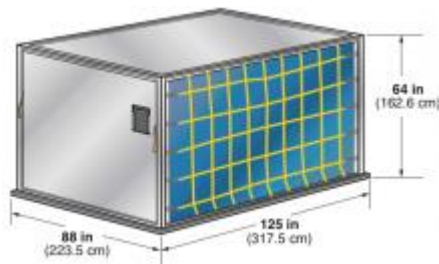

## ULD Container Type: LD-9

- **IATA ULD code:** AAP enclosed pallet on P1P base
- **Rate class:** Type 5
- **Description:** General-purpose enclosed container fitted to P1P base. Door is canvas with built-in net door straps, or solid.
- **Suitable for:** 747, 767, 777, 787, DC-10, MD-11 lower hold
- **Door opening:** 118 x 58 in (300 x 147-cm)
- **Maximum gross weight:** Lower hold, 4,624 kg (10,194 lb); main deck, 6,000 kg (13,227 lb)
- **Tare weight:** Canvas door, 215 kg (473 lb); solid door, 270 kg (595 lb)
- **AS1825 volume:** 10.8 m<sup>3</sup> (381 ft<sup>3</sup>)
- **Boeing volume:** 10.8 m<sup>3</sup> (381 ft<sup>3</sup>)



## ULD Container Type: LD-9 Reefer

- **IATA ULD code:** RAP cool container on P1P base
- **Rate class:** Type 5
- **Description:** Insulated container with solid door. Suitable for: 747, 767, 777, 787, DC-10, MD-11 lower hold
- **Door opening:** 85 x 58-in (216 x 147-cm)
- **Maximum gross weight:** Lower hold, 4,626 kg (10,198 lb); main deck, 6,000 kg (13,227 lb)
- **Tare weight:** 400 kg (882 lb)
- **Internal volume:** 9.6 m<sup>3</sup> (339 ft<sup>3</sup>)

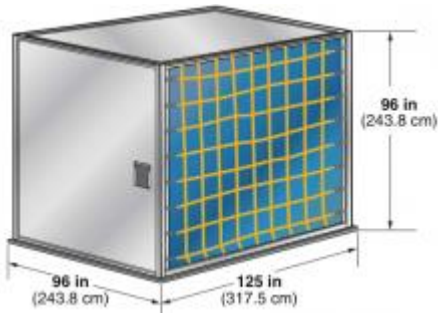

## ULD Container Type: M-1

- **IATA ULD code:** AMA rectangular container on P6P base
- **Prefixes:** AMF, AMG, AMK, AMP, AQA, AQD, and AQ6
- **Rate class:** Type 2
- **Description:** Main-deck container. Door is canvas with built-in net door straps.
- **Suitable for:** 747F, 747 Combi, 777F center loading only
- **Maximum gross weight:** 6,804 kg (15,000 lb)
- **Tare weight:** 350 kg (772 lb),
- **AS1825 volume:** 17.6 m<sup>3</sup> (623 ft<sup>3</sup>)

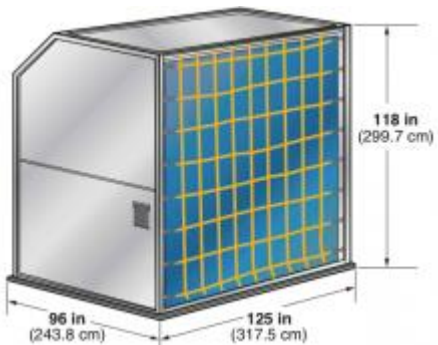

## ULD Container Type: M-1H

- **IATA ULD code:** AMD contoured
- **Rate class:** Type 2H
- **Description:** Main-deck upper contoured container. Door is canvas with built-in net door straps.
- **Suitable for:** 747F, 747 Combi, 777F center loading only
- **Maximum gross weight:** 6,800 kg (14,991 lb)
- **Tare weight:** 370 kg (816 lb)
- **AS1825 volume:** 21.2 m<sup>3</sup> (750 ft<sup>3</sup>)



## ULD Container Type: M-2

- **IATA ULD code:** AGA 20-ft box container
- **Prefixes:** ASE
- **Rate class:** Type 1
- **Description:** Main-deck container. Door is solid.
- **Suitable for:** 747F, 747 Combi (243.8 cm) 777F center loading only 238.5 in
- **Maximum gross weight:** 11,340 kg (25,000 lb)
- **Tare weight:** 1,000 kg (2,204 lb)
- **AS1825 volume:** 33.7 m<sup>3</sup> (1,190 ft<sup>3</sup>)

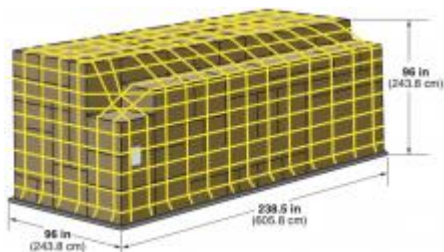

## ULD Container Type: M-6

- **IATA ULD code:** PGA 20-ft flat pallet with net
- **Prefixes:** PGA, PGE, PGF, PSA, PSG, P7E, P7F, and P7G
- **Rate class:** Type 1
- **Description:** Main-deck pallet squared off to 244 cm (96 in) high.
- **Suitable for:** 747F, 747 Combi, 777F
- **Maximum gross weight:** 11,340 kg (25,000 lb) (605.8 cm)
- **Tare weight:** 500 kg (1,102 lb)
- **AS1825 volume:** 33.7 m<sup>3</sup> (1,190 ft<sup>3</sup>)

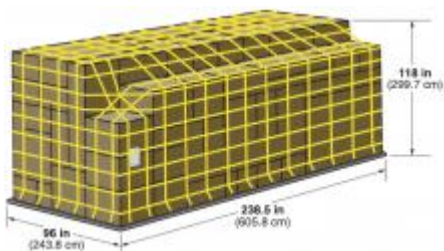

## ULD Container Type: M-6 (118\"H)

- **IATA ULD code:** PGA 10-ft high, 20-ft flat pallet with net
- **Prefixes:** PGA, PGE, PGF, PSA, PSG, P7A, P7E, P7F, and P7G
- **Rate class:** Type 1
- **Description:** Main-deck pallet squared off to 299.7 cm (118 in) high.
- **Suitable for:** 747 Combi, 777F 238.5 in 747F through side cargo door only
- **Maximum gross weight:** 11,340 kg (25,000 lb)
- **Tare weight:** 500 kg (1,102 lb)
- **AS1825 volume:** 39.6 m<sup>3</sup> (1,400 ft<sup>3</sup>)

